

eMag 43

Instructions for use
for the electronic magnifier

EN

eMag 43 Handheld video magnifier

Instructions for use

Congratulations on your purchase of the eMag 43. This electronic handheld magnifier allows you to magnify printed text and objects from 2 to 14 times the object's original size. The eMag 43 features a 4.3-inch, wide-screen (16:9 aspect ratio) LCD display. We hope you enjoy using this high-quality device. The information and data contained in this document are subject to change without notice. No part of this document may be reproduced or transmitted in any form or by any means, electronic or mechanical, or for any purpose, without the express written approval of A. SCHWEIZER GmbH.

Distributor

A. SCHWEIZER GmbH
Hans-Böckler-Straße 7
91301 Forchheim, Germany
www.schweizer-optik.de

Service and support

If you require technical support with your eMag 43, please contact the dealer who sold you the visual aid. It is recommended you first refer to “Troubleshooting” (on page 18).

Note: The eMag 43 contains no user serviceable components. Any unauthorised attempt to service or replace internal components will render the warranty null and void.

Table of contents

eMag 43 – overview	4	Technical data	20
Intended use, Clinical Use, Intended Users,		Safety and maintenance	21
Intended Usage Environment	4	Cleaning the eMag 43 housing	22
What's in the box?	5	Cleaning the eMag 43 LCD screen	22
Carrying the eMag 43	5	Battery safety instructions	23
eMag 43 Components	6	Symbol guide	24
Quick start	8		
Inserting batteries	8		
Charging batteries	10		
Battery status LED	11		
Using the eMag 43	12		
Reading with the eMag 43	12		
Magnifying an image	13		
Magnification level with handle collapsed	14		
Magnification level with handle extended	14		
Freezing and magnifying an image	15		
Saving and deleting an image	16		
Saving an image when the memory is full	17		
Turn LED Lights Off	17		
Troubleshooting	18		

eMag 43 – overview

Intended use

This electrical device serves to electronically enlarge objects or for reading printed materials in everyday use.

Clinical Use

This electrical device contributes significantly to daily tasks, facilitates independence, increases productivity and improves self-esteem.

Intended Users

This device is for people with visual impairments or for others who would like to view text, pictures or objects enlarged.

Intended Usage Environment

This device is intended for use at home, at the office and out and about. It is for enlarging and improving pictures and texts for users.

What's in the box?

Before using the eMag 43, please take out and verify all the items that are in the box:

- eMag 43 electronic handheld magnifier
- AC power adapter with four international adapters
- Four AAA nickel-metal hydride (NiMH) rechargeable batteries
- Carrying case with shoulder strap
- Wrist strap
- eMag 43 User's Guide

Carrying the eMag 43

The eMag 43 has a wrist strap that you can use to carry it comfortably and safely. To attach the strap, do the following:

1. Push one end of the strap through the hole in the wrist strap post that is located on the rear of the eMag 43.
2. Loop one end of the wrist strap through the other end of the wrist strap and pull the strap tight.

When using the eMag 43, you can now place your hand in the wrist strap. This helps protect the eMag 43 from falling if you let it go of by accident.

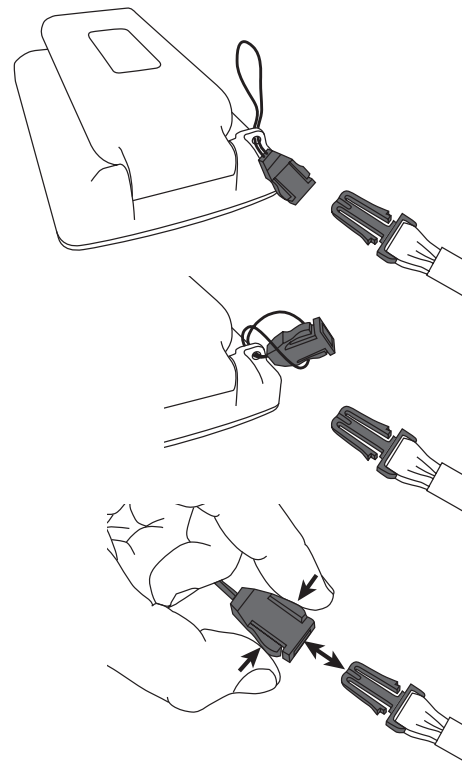

eMag 43 Components

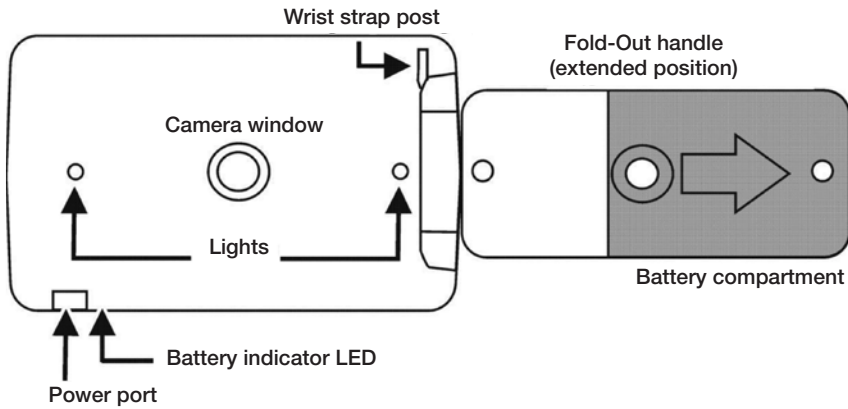
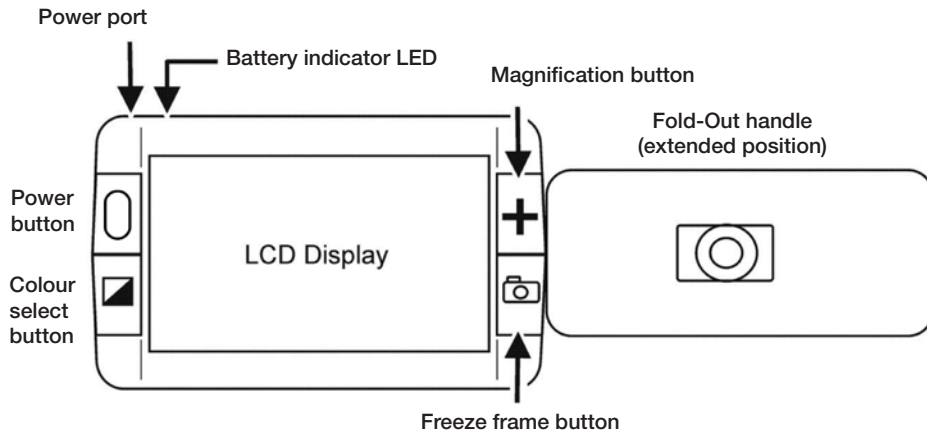

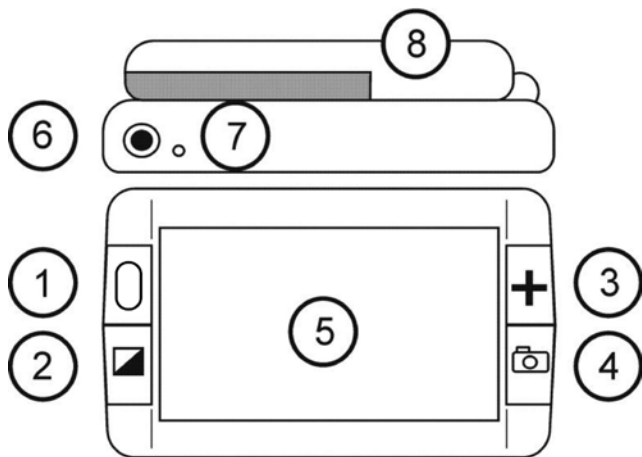

- 1 Power button (green)
- 2 Colour select button (blue)
- 3 Magnification button (yellow)
- 4 Freeze frame button (red)
- 5 LCD screen
- 6 Power port
- 7 Battery indicator LED
- 8 Handle and battery compartment
- 9 Lights
- 10 Camera window
- 11 Wrist strap post

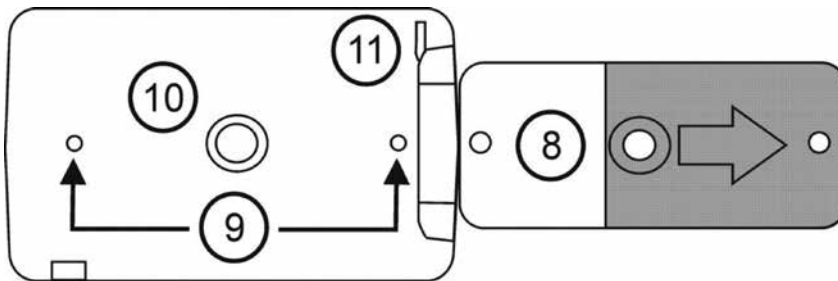

eMag 43 front and top view



eMag 43 rear view

Quickstart

Note: Before using the eMag 43 electronic handheld magnifier, you must charge the unit. The batteries charge faster when the unit is off. Allow at least two hours for a complete charge before using the unit for the first time. Please observe the "Inserting and Charging the Batteries" chapter.

The eMag 43 is easy to use, even for those unfamiliar with assistive technology. Press the green/yellow **power**  button to turn the unit on. Hold or place the eMag 43 over an object and adjust the magnification to your preference using the yellow **magnification**  button. The magnified image appears on the unit's display. For safety reasons, eMag 43 turns off automatically after 30 minutes if no button is pressed during that time. The following describes the location of the eMag 43 components and the LED operation.

Inserting batteries

To insert the batteries, do the following:

1. Hold the eMag 43 in one hand. With the other hand, rotate and swing the handle until it is fully extended as shown in the following illustration.

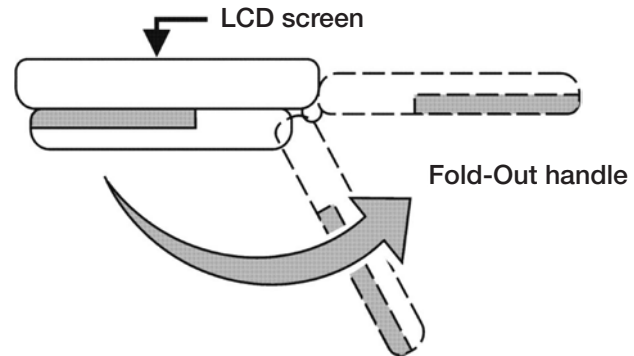

2. Turn the eMag 43 so that the LCD display is facing away from you, then slide the battery cover in the direction of the arrow shown in the following illustration.

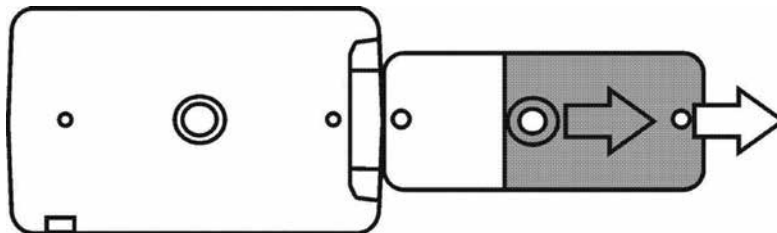

Note: Observe the correct polarity of the batteries when inserting. Insert the batteries as shown in the following illustration.

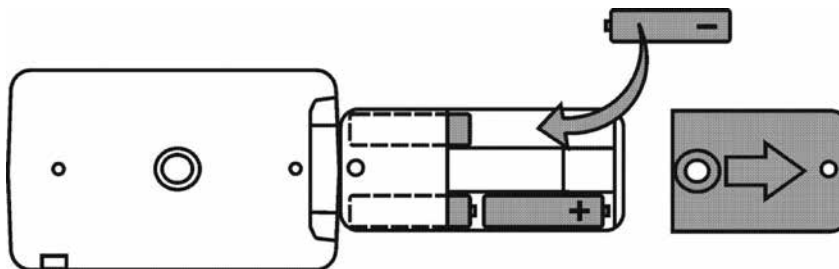

3. Close the battery cover again.

Charging batteries

To charge NiMH batteries, do the following:

1. Plug the small end of the power adapter into the power port. The port is located on the left top-edge of the unit next to the LED as shown in the following illustration.

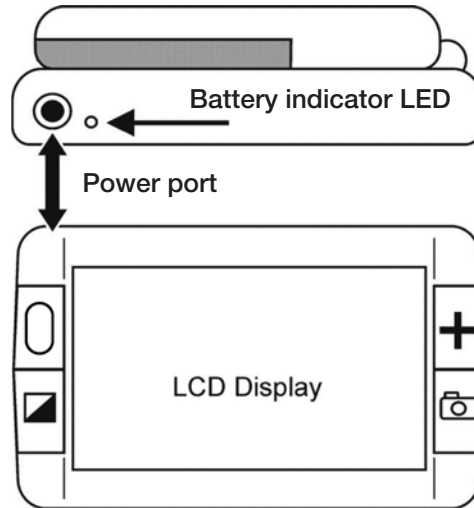

2. Plug the other end of the power adapter into a standard AC outlet. The battery indicator LED blinks green to show that the batteries are charging.
3. Once the batteries are charged, the LED stops blinking and glows a steady green. Unplug the power adapter from the eMag 43. The battery indicator LED turns off.

Battery status LED

- Green solid:** Batteries are charged, power adapter connected.
- Green flashing:** Batteries are charging, power adapter connected.
- Red flashing:** Low battery status.
- Red solid:** Error: disconnect power adapter, wait a few seconds and then reconnect it.
- No LED:** Batteries are charged, the power adapter is not plugged in or the eMag 43 is off.

Your eMag 43 is now ready for up to two hours of continuous use. When the batteries are low, the battery indicator LED flashes red. Connect the **power adapter** and plug it in to recharge the batteries.



Note: Please note that after 30 minutes the eMag 43 switches to energy-saving mode (screen goes blank) if no key is pressed during this time. Press the On/Off Button to reactivate the eMag 43.

Using the eMag 43

After charging the batteries, you are ready to begin reading with the eMag 43. With the unit's powerful magnification features, you can read or view letters, menus, maps, photos, labels, bus and train schedules, television listings, receipts, ingredients, and much more.

Reading with the eMag 43

To read by using the eMag 43, do the following:

1. Make sure that the unit is charged.
2. Press the green/yellow **power**  button to turn on the eMag 43. After a few seconds, the LCD displays the current view as seen through the camera window.
3. If you are reading a book, letter, or other printed item, place it on a flat surface, such as a table or desk.
4. You can then hold the eMag 43 by its handle the same way as you would hold a normal magnifying glass, or you can fold the handle under the unit and place the eMag 43 directly over the text or object that you want to read or view. Anything under the unit is magnified and shown on the screen.
5. Adjust the zoom using the yellow **magnification**  button located on the left side next to the LCD.
6. Select a colour mode by pressing the blue **colour select**  button located on the left side of the screen. Five different video modes are available: Normal (full colour), White on Black (enhanced positive), Black on White (enhanced negative), Yellow on Blue and Yellow on Black.
7. Move or slide the unit to the right to read to the end of the line. Slide the unit first to the left and then down to read the next line of text.

For safety reasons, eMag 43 turns off automatically after 30 minutes if no button is pressed during that time.

Magnifying an Image

The eMag 43 has three digital zoom settings. Depending on the position and placement of the unit, it supports screen magnification levels from **2x** to **14x**.

1. To increase screen magnification, press the yellow **magnification +** button.
2. To step up to the next level of magnification, press the yellow **magnification +** button again.
3. Pressing the yellow **magnification +** button a third time returns the eMag 43 to its initial magnification level.

For more information about the different magnification levels, please refer to the following section.

Magnification level with handle collapsed

When the eMag 43 is placed on a document, the starting magnification is **5x**.



By pressing the yellow **magnification +** button repeatedly, the magnification increases to **7.5x**, to **10x**, and then back to **5x**.

Magnification level with handle extended

When the eMag 43 is held over a document (as shown in the illustration), the starting magnification is **2x**.

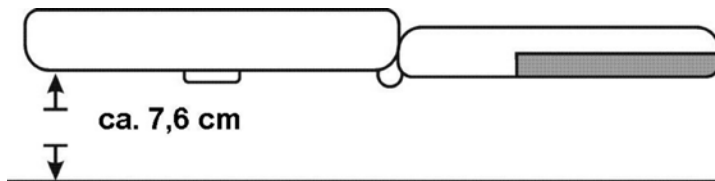

Magnification level **2x** while holding the eMag 43 approximately 7.6 cm above item.

By pressing the yellow **magnification +** button repeatedly, the magnification increases to **3x**, to **4x**, and then back to **2x**.

When the eMag 43 is in this low position (approx. 1.3 cm) above a document, the starting magnification is **7x**.





By pressing the yellow **magnification +** button repeatedly, the magnification increases to **10.5x**, to **14x**, and then back to **7x**.

Freezing and magnifying an image







Freezing an image can be useful for reading labels on items on a store shelf, for example. By holding the eMag 43 close to the item and capturing the image, you can then hold the unit close enough for you to read.

To freeze the current image on the LCD screen, do the following:

1. Press the red **freeze frame**  button.
2. If you wish, you can change the magnification of the picture taken by pressing the yellow **magnification +** button.
3. Press the red **freeze frame**  button again to turn off the freeze frame mode.



Saving and deleting an image

Switch on the eMag 43 (press the green/yellow button ). Then press the red button  to take the desired image. The image on the display can be saved as follows

- Press  and **HOLD this red button for 6 seconds** to enter Storage mode.
- The check box in the lower left corner will be automatically checked. This indicates that the image will be stored when you exit Storage mode.
- The Forwards symbol is now displayed in the bottom right corner  Press the red button  to advance to the next image. Press the button  repeatedly to advance through all the images saved in the **eMag 43**
- To delete an image, press the blue button  to clear the check box The image is deleted when you exit Storage mode.
- Press and HOLD the red button  for **3 seconds** to leave Storage mode.
- To view stored images press and HOLD the red  button for **6 seconds**. You will then enter Storage mode You can then advance through the images as previously described in this section.





Saving an image when the memory is full

The eMag 43 can store a maximum of 15 images. If you try to store another image, the "Memory full"  icon is displayed in the bottom left corner. Before you can save another image you must delete one or more images from the memory:

- Press the red button  to advance to the desired image and then press the blue button  to clear the check box.
- Press and HOLD the red button  for **3 seconds** to leave Storage mode. The new image is saved, and all unchecked images are deleted.

Turn LED Lights Off

To avoid glare when viewing reflective surfaces you can turn off the LED lights.

- Press and HOLD  the green/yellow button and then press the red button . The LED lights turn off.
- To turn on the lights again, press and HOLD the green/yellow button  and then press the red button .

Troubleshooting

Problem	Solution
The screen is blank.	Ensure that the power is on. Verify that the item you want to magnify is positioned correctly under the camera window. Reduce the magnification level. Charge the NiMH batteries. If using AAA alkaline batteries, replace the alkaline batteries. (Do not mix NiMH batteries and alkaline batteries.)
The unit does not turn on.	Charge the NiMH batteries. If using AAA alkaline batteries, replace the alkaline batteries. (Do not mix NiMH batteries and alkaline batteries.)
The image on the screen is dark or distorted.	Make sure that the eMag 43 is positioned flat on the page you are reading.
The battery indicator LED is flashing red.	Charge the NiMH batteries, or, if using AAA alkaline batteries, replace the alkaline batteries. (Do not mix NiMH and alkaline batteries.)
The battery LED is solid red while the power adapter is connected to the eMag 43.	A battery error has occurred. Unplug the power adapter from the eMag 43 and plug it in again. Charge the NiMH batteries for at least 2 hours. If using AAA alkaline batteries, replace the alkaline batteries. If the problem continues, disconnect the power adapter and call your eMag 43 merchant.

Problem	Solution
The battery indicator LED does not flash green, even though the power adapter is connected and plugged into a wall socket.	Ensure that the small end of the power adapter is properly plugged into the unit's power port. Ensure that the outlet has power and is not malfunctioning. If the wall outlet is connected to a wall switch, make sure that the switch is on.
The NiMH batteries are not charging.	Ensure that the small end of the power adapter is properly plugged into the unit's power port. Ensure that the batteries are inserted properly. Observe the correct polarity. Ensure that the outlet has power and is not malfunctioning. If the wall outlet is connected to a wall switch, make sure that the switch is on.
There are smudges or blemishes on the screen.	Clean the LCD display and the camera window.
The text is too small to read.	Press the yellow magnification + button to increase the magnification level.
The text is too large to read.	Press the yellow magnification + button to cycle through to a lower magnification level.

Technical data

LCD screen:	4.3 inches (109 mm) widescreen (16:9 aspect ratio)
Dimensions:	126 mm (height) x 75 mm (width) x 32 mm (depth), with folded handle
Weight:	218 g
Colour modes:	5 default colour modes (true full colour, white on black, black on white, yellow on blue, yellow on black)
Magnification:	2 x to 14 x, in 3 levels
Maximum number of saved images:	15 images
Batteries:	4 rechargeable AAA NiMH batteries (1000 mAh), approx. 2 hours continuous use; charging time approx. 2 hours or 4 AAA single-use alkaline batteries

Note: Only use the supplied power adapter to charge the eMag 43 battery.

Manufacturer

Vispero
Pesetastraat 5a
2991 XT Barendrecht
Nederland



Class 1 LED Product



RoHS



Safety and maintenance

- Do not attempt to repair the eMag 43 yourself or open the housing. This product contains no user serviceable parts. Any unauthorised attempt to service or replace internal components will render the warranty null and void.
- Do not remove the battery. It is not user serviceable.
- Keep the eMag 43 away from wet areas, rain and other sources of moisture.
Do not immerse the eMag 43 in water.
- Always operate the eMag 43 at an ambient temperature between 10° and 35° C.
- Never store the eMag 43 in places subject to temperature extremes such as a parked car.
- Do not force any connector into the power port of the eMag 43. The power connector fits easily into the port.

Cleaning the eMag 43 housing

Make sure the eMag 43 is unplugged. Use a slightly dampened, soft, clean cloth with water or a mild detergent. Do not use alcohol, solvents, abrasives or aerosol sprays.

Cleaning the LCD screen

- Power off and unplug the eMag 43 before cleaning the LCD screen.
- Always use a clean microfibre cloth.
- Very gently wipe the cloth across the screen. Do not exert pressure on the cloth or the LCD screen.
- If you use a liquid detergent, it must be suitable for use on LCD screens. You can also use distilled water, isopropyl alcohol or vinegar mixed with water at a concentration of no more than 10 percent vinegar. Please note that tap or mineral water may cause spotting on the screen. Do not leave any liquid on the screen. Repeat this procedure for any marks that are hard to remove.
- NEVER spray detergent directly on the LCD screen.
- NEVER use a cleanser that contains acetone, ethyl alcohol, ethyl acid, ammonia or methyl chloride.
- NEVER use paper towels to clean the LCD screen.

Battery safety instructions







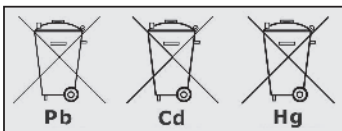









We place our batteries on the market in line with legal requirements. Please read the points below for the safe removal and disposal of our batteries:

- Our product contains a rechargeable battery.
- To prevent harmful effects to the environment and health, used batteries must be disposed of properly at recycling centres or returned to the point of sale. Returning batteries is required by law and free of charge for you.
- Batteries should only be returned in a fully discharged state. The poles of lithium-ion batteries must be insulated with adhesive tape.
- Valuable raw materials such as zinc, iron, nickel and so on can be recovered by recycling used batteries.
- The “crossed out wheeled bin” symbol indicates that disposal of used batteries along with normal refuse is illegal.

The additional specification of the chemical symbols for lead (Pb), cadmium (Cd) and mercury (Hg) indicates that these materials are contained in the batteries in legally permissible quantities.



Symbol guide

	Item no
	Batch number
	Serial number
	Medical device
	Authorised representative
	Manufacture
	Manufacture date
	Barcode
	Fragile, handle with care
	Protect from moisture
	Warning
	Consult instructions for use
	Disposal information
	Power supply
	Declaration of conformity
	CE marking of conformity

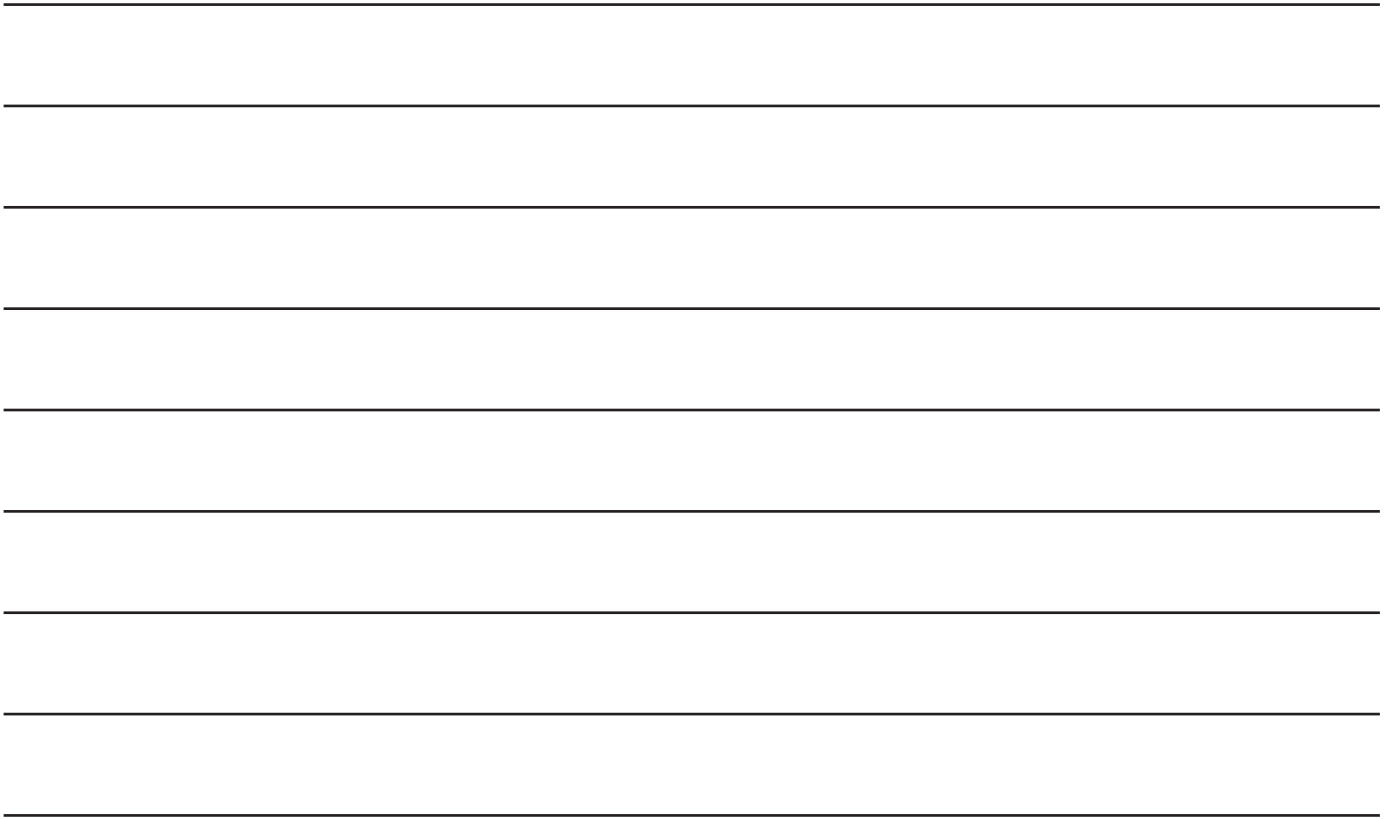

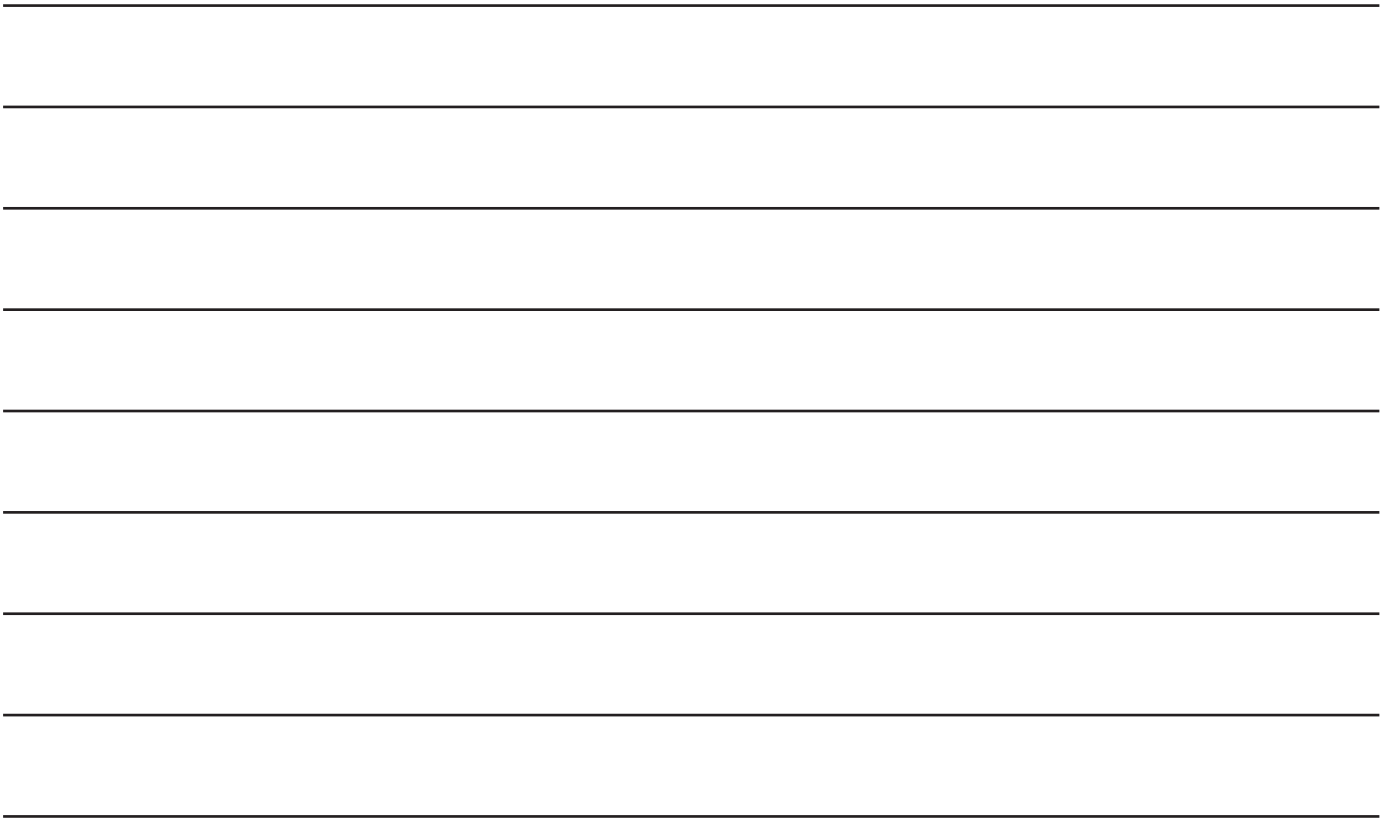

A. SCHWEIZER GmbH
Hans-Böckler-Straße 7, 91301 Forchheim, Germany
Phone +49 9191-72100, Fax +49 9191-721072
info@schweizer-optik.de, www.schweizer-optik.de

23-046/313358-EN/02